

4A Fit Back Deck into Position.

- A. Insert the Back Deck lying flat. Insert one end first, then gently lower the other end into position.

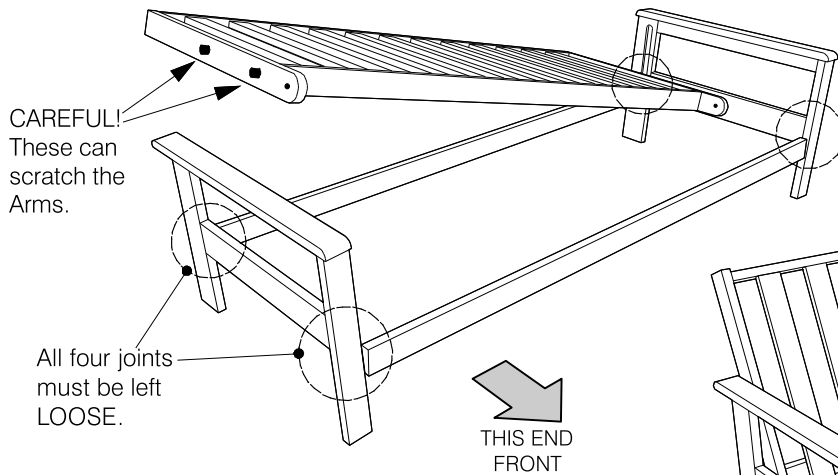

- B. When you have the Back Deck fitted lying flat, tighten all the Bolts. From the back, lift the Back Deck to upright as illustrated.

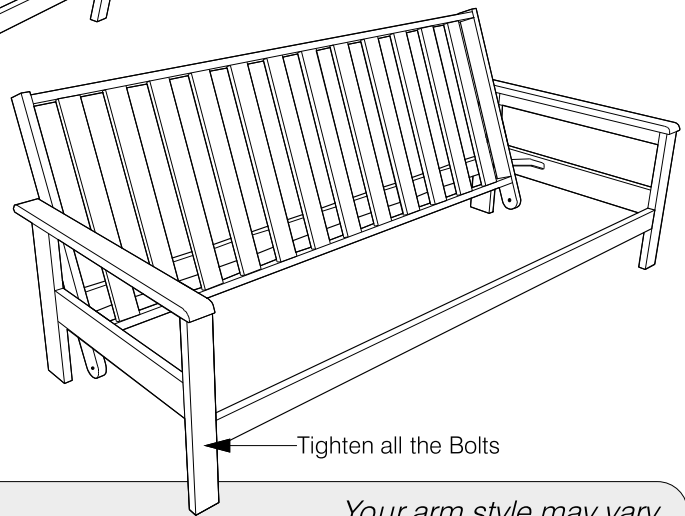

Your arm style may vary

- ✓ This step can be tricky - it is best done with two people
- ✓ Remember that the Bolts on the Arm should be LOOSE.
- ✗ Be careful not to scratch the Arms with the Plastic Runners when you lower the ends of the Back Deck.

4B Fit Seat Deck into Position.

Your arm style may vary

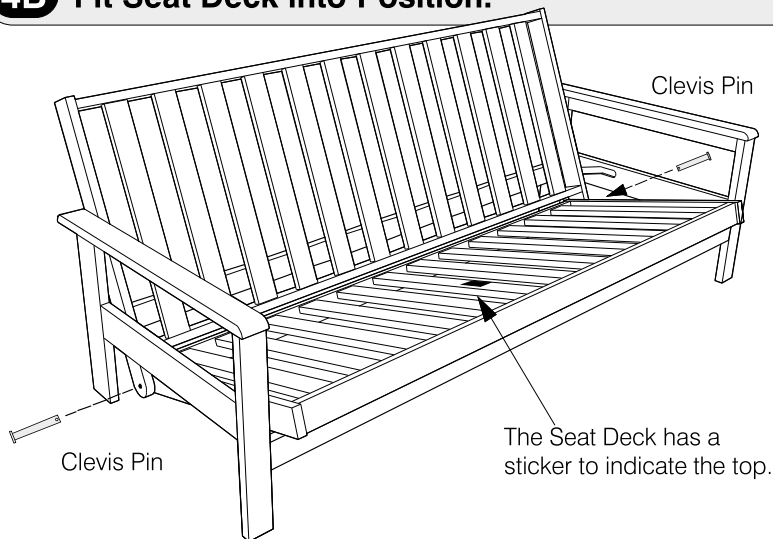

Fit the seat deck between the Arms and into the Back Deck as shown. Use the Clevis Pins to connect the two decks. Secure with a Washer and Locking Pin.

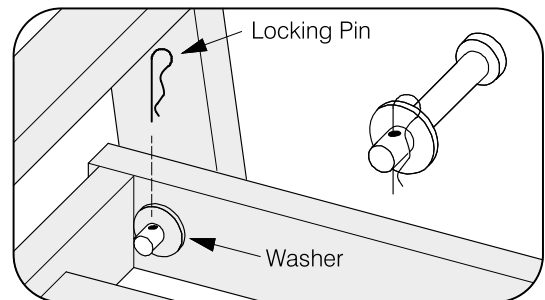

4C For Queen size frame only: Attach short legs

Your arm style may vary

