

STEP 3:

HOOK 2PCS CROSS BAR (F) INTO THE BACK OF LOWER SIDE OF THE FRAME (A) (B). USE BOLTS (J) TO THE ABOVE HOLE OF THE CROSS BAR .USE BOLTS (J) AND NUTS (P) TIGHTEN CROSS BARS. HINT PUT BOLTS THRU OUTSIDE OF ARMS AND THE NUTS ON THE INSIDE OF ARM WHERE THE TRANSMISSION PARTS ARE.

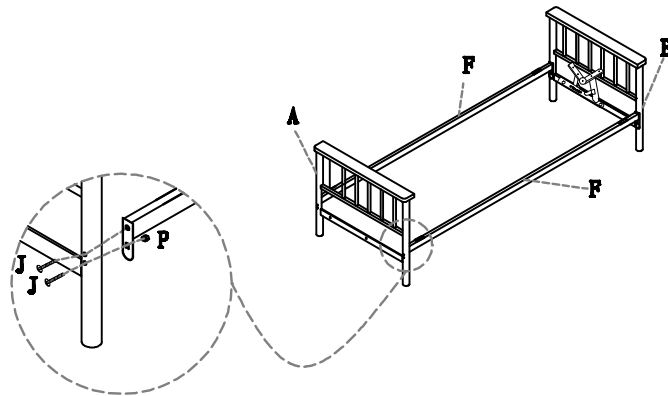

STEP 4:

ATTACH BACK MATTRESS FRAME (D) TO TRANSMISSION (G) (H). THEN USE BOLTS (K) AND NUTS (P) TO TIGHTEN THEM ASSEMBLE FRONT MATTRESS FRAME (C) AS ABOVE DESCRIPTION. PRESS THE HOOK (I) INTO THE HOLE OF THE MATTRESS FRAMES

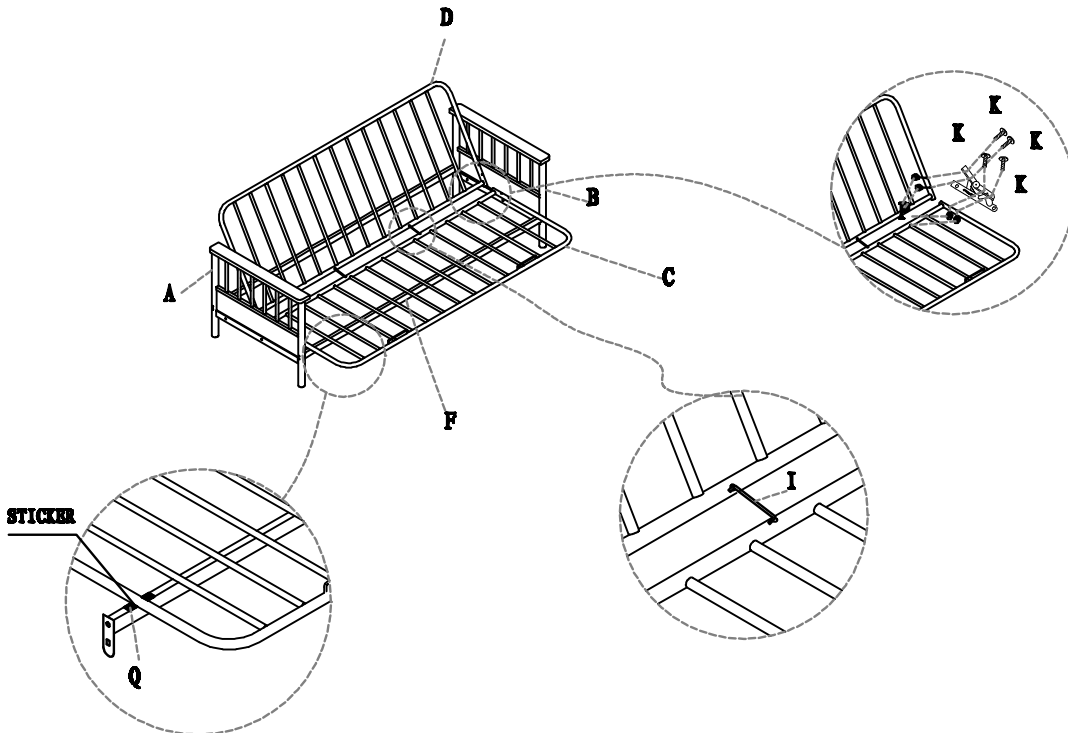

LAST STEP , PLACE FOUR PCS OF STICKERS UNDER THE DECKS. JUST LAY BOTH THE SEAT AND BACK DECKS DOWN AND PLACE STICKER PADS ON THE TOP OF THE RAILS WHERE THE SEAT AND BACK MEET THE RAILS.