



ASSEMBLY INSTRUCTION

BIFOLD ARMS
LODGE

See below for
Preparation of arms
for assembly

1 One pair of Bifold Arms

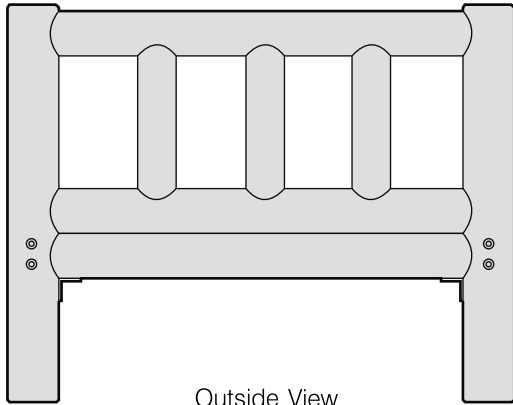

Outside View

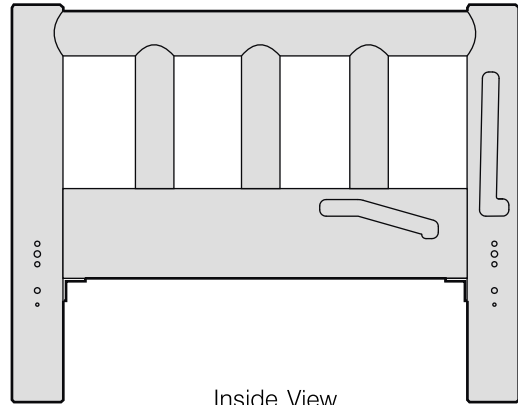

Inside View

2 Parts in this box.



120 mm bolts x 8 Pieces



Barrel nuts
x 8 Pieces

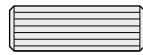

Wooden dowel
x 4 Pieces



Allen Key x 1 Piece

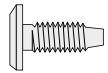

16mm Bolts
x 4 Pieces



Wood Button
x 8 Pieces

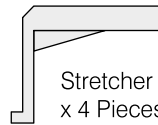

Stretcher Bracket
x 4 Pieces

3 Fasten Stretcher Brackets to Arm.

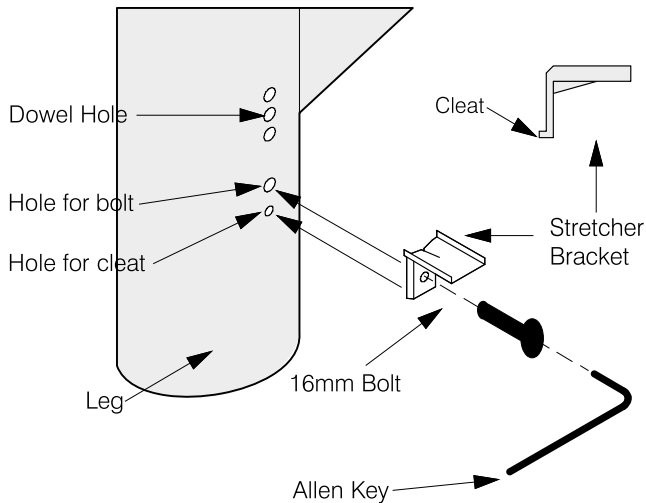

- A. Insert the Stretcher Bracket Cleat into the hole provided.
- B. **IMPORTANT:** Don't fully tighten Bracket until Stretchers are all in place for easy alignment.
- C. Each arm requires two brackets, front and back.

4 Assemble the Bifold Body

BODY INSTRUCTIONS: Instructions for assembly of arms to Bifold Body are in the BODY box.

NOTE: Fitting Wooden Dowels

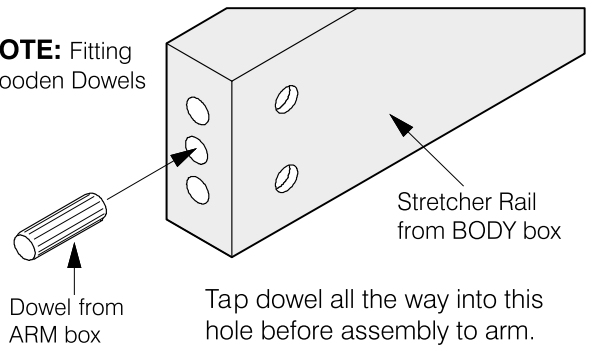

5 Fit Wood Buttons Into Arm Holes.

AFTER TOTAL ASSEMBLY:

Tighten all bolts.
Push fit or lightly tap the Wooden Buttons into the Bolt holes on the Arms.

